

FEATURES & STANDARDS

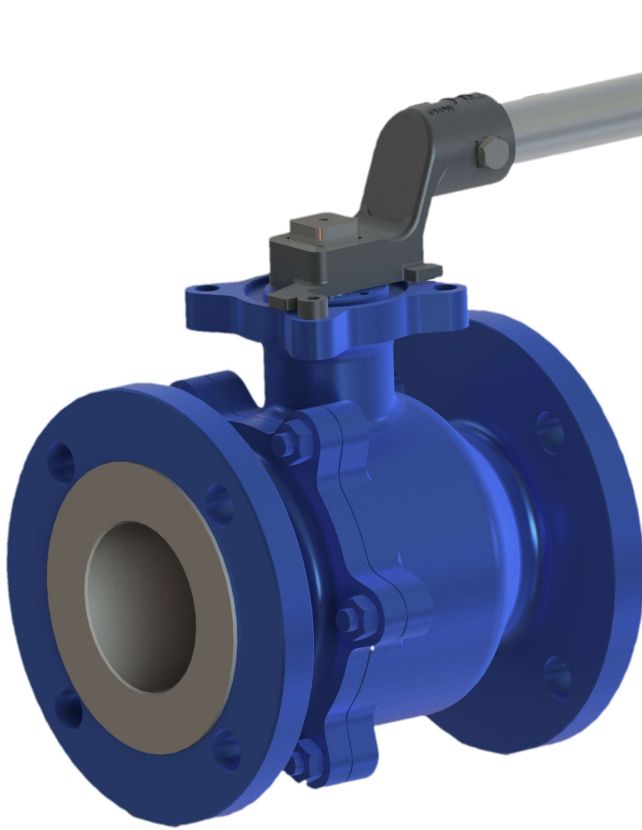

- Industry leading warranty (24 months*)
- Standard Cast (150 – 600 ASME).
- Triple independent low emission stem seals
- Valve stem rotation independent of gland nut ensuring full integrity of stem seal thus long life
- Blow-out proof stem
- AED O-rings (anti-explosive decompression)
- Standard seats** : PTFE (150 – 300 ASME); Devlon
- Standard seals** : VITON B , Graphite , PTFE
- Double anti-static protection
- Low torques with special wide seat design
- General Standards include: API 608, API 6D, ISO 17292, BS-5351, ASME B16.34
- Sour service: NACE MR0175 & ISO 15156
- Fire safe design (API 607)
- Standard ISO 5211 mounting pads
- Testing includes high pressure hydro and low air seat test
- Cavity fillers available
- Low emission packing
- GFT thrust-washer and DELRIN gland bearing prevents galling & prevents against deformation

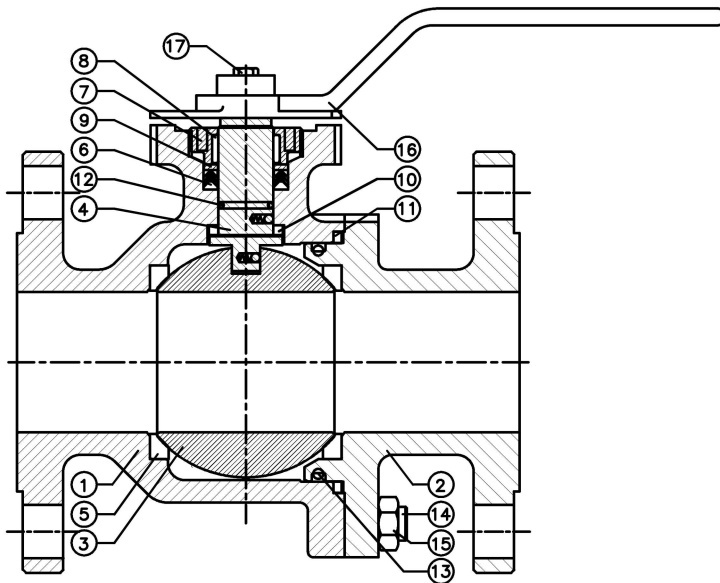

MANUFACTURING RANGE

(Available in full and regular port)

	150 ASME PN 25	300 ASME PN 50	600 ASME PN 100	900 ASME PN 150
1/2"	•	•	•	•
3/4"	•	•	•	•
1"	•	•	•	•
1 1/4"	•	•	•	•
1 1/2"	•	•	•	•
2"	•	•	•	•
2 1/2"	•	•	•	•
3"	•	•	•	•
4"	•	•	•	•
6"	•	•	•	•
8"	•	•	•	•
10"	•	•	•	•

ITEM	DESCRIPTIONS
1	BODY
2	END CONNECTOR
3	BALL
4	STEM
5	SEAT
6	STEM SEAL
7	GLAND

ITEM	DESCRIPTIONS
8	GLAND BEARING
9	SPACER
10	STEM TRUST WASHER
11	BODY SEAL
12	STEM 'O' RING
13	BODY 'O' RING
14	STUD

ITEM	DESCRIPTIONS
15	NUT
16	LEVER
17	STOPPER
18	ALLEN BOLT
19	TAG PLATE
20	
21	

NOTE: Gear operator and lifting lugs supplied on sizes 6" and larger.
 Drawings are representative, please contact Sankey Controls for specific and current PDF drawings.
 *Sankey limited warranty of 24 months from date of shipment or 18 months from the date of start-up.
 ** Other materials available upon request.