

FEATURES & STANDARDS

- Industry leading warranty (24 months*)
- Standard Cast (150 – 300ASME).
- Triple independent low emission stem seals
- Valve stem rotation independent of gland nut ensuring full integrity of stem seal thus long life
- Blow-out proof stem
- AED O-rings (anti-explosive decompression)
- Standard seats** : PTFE (150 – 300 ASME)
- Standard seals** : Graphite , PTFE
- Double anti-static protection
- Low torques with special wide seat design
- General Standards include: BS-5351, ASME B16.34
- Upto 96% cavity free design
- Sour service: NACE MR0175 & ISO 15156
- Fire-safe tested & certified API-607
- Gear operator and lifting lugs – 4” bore and larger
- Standard ISO 5211 mounting pads
- Low emission packing
- GFT thrust-washer and DELRIN gland bearing prevents galling & prevents against deformation

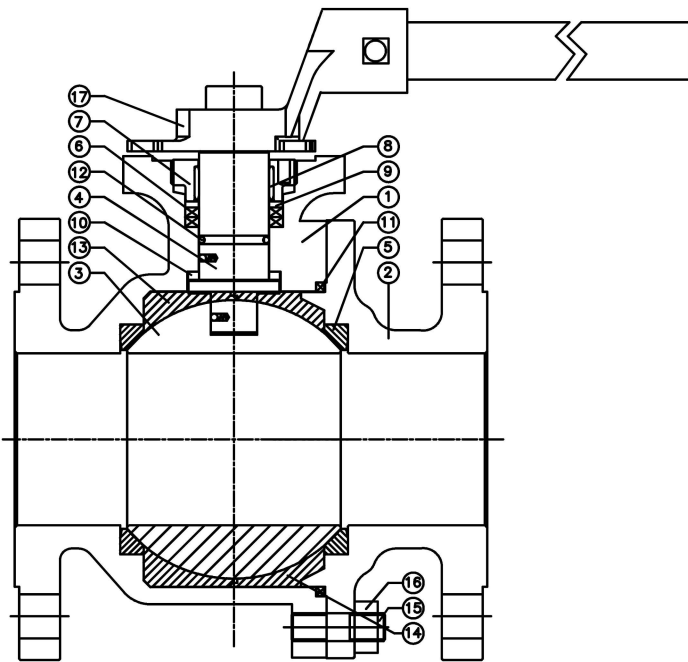

MANUFACTURING RANGE

(Available in full port)

	150 ASME PN 25	300 ASME PN 50
1/2"	•	•
3/4"	•	•
1"	•	•
1 1/4"	•	•
1 1/2"	•	•
2"	•	•
2 1/2"	•	•
3"	•	•
4"	•	•
6"	•	•
8"	•	•

ITEM	DESCRIPTIONS
1	BODY
2	END CONNECTOR
3	BALL
4	STEM
5	SEAT
6	STEM SEAL
7	GLAND

ITEM	DESCRIPTIONS
8	GLAND BEARING
9	SPACER
10	STEM TRUST WASHER
11	BODY SEAL
12	STEM 'O' RING
13	CAVITY 1
14	CAVITY 2

ITEM	DESCRIPTIONS
15	STUD
16	NUT
17	LEVER
18	STOPPER
19	ALLEN BOLT
20	TAG PLATE
21	

NOTE: Gear operator and lifting lugs supplied on sizes 6” and larger.
 Drawings are representative, please contact Sankey Controls for specific and current PDF drawings.
 *Sankey limited warranty of 24 months from date of shipment or 18 months from the date of start-up.
 ** Other materials available upon request.