

FEATURES & STANDARDS

- Industry leading warranty (24 months*)
- Solid cast (150 – 300 ASME).
- Triple independent low emission stem seals
- Valve stem rotation independent of gland nut ensuring full integrity of stem seal thus long life
- Compact Non-Standard Face to face dimensions.
- Low sump area.
- Standard seats** : PTFE (150 – 300 ASME)
- Standard seals** : Graphite , PTFE
- Double anti-static protection
- Low torques with special wide seat design
- General Standards include: BS-5351, ASME B16.34
- Angled stem design to facilitate actuator mounting
- Adjustable and maintenance free stem sealing with additional O-ring
- Cavity filler also available
- Unique push fit design ,easy maintenance capability
- Low emission packing
- GFT thrust-washer and DELRIN gland bearing prevents galling & prevents against deformation.
- Metal to metal sealing system for high pressure, high temperature and abrasive operating conditions.

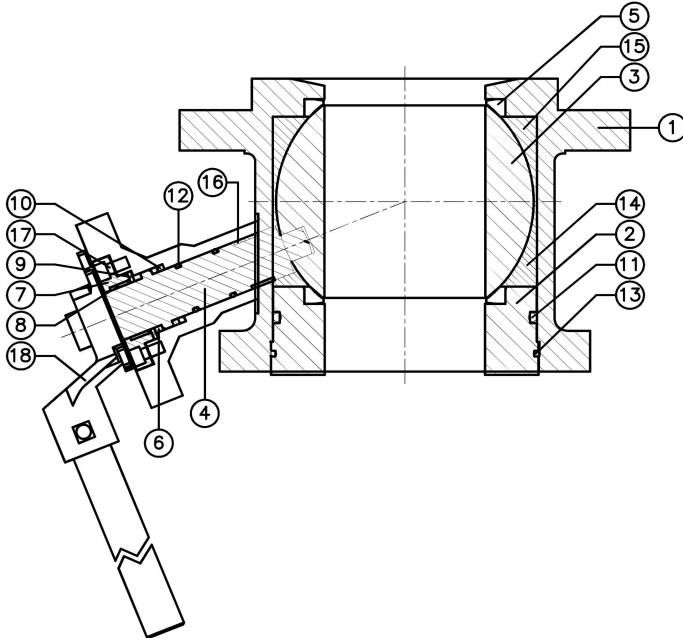

MANUFACTURING RANGE

(Available in full port)

Bottom Valve Outlet	Vessel Pad Flange	150 ASME PN 25	300 ASME PN 50
1" x 2"		•	•
1 1/2" x 2 1/2"		•	•
2" x 3"		•	•
2 1/2" x 4"		•	•
3" x 4"		•	•
4" x 6"		•	•
6" x 10"		•	•
8" x 12"		•	•
10" x 14"		•	•

ITEM	DESCRIPTIONS
1	BODY
2	INSERT
3	BALL
4	STEM
5	SEAT
6	STEM SEAL
7	GLAND

ITEM	DESCRIPTIONS
8	GLAND BEARING
9	SPACER
10	STEM SEAL
11	INSERT SEAL
12	STEM 'O' RING
13	INSERT 'O' RING
14	CAVITY 1

ITEM	DESCRIPTIONS
15	CAVITY 2
16	STEM BEARING
17	GLAND BOLTS
18	HANDLE
19	TAG PLATE
20	
21	

NOTE: Drawings are representative, please contact Sankey Controls for specific and current PDF drawings.
 *Sankey limited warranty of 24 months from date of shipment or 18 months from the date of start-up.
 ** Other materials available upon request.