

Full Port in Flanged / Screwed / Weld End Connections

FEATURES & STANDARDS

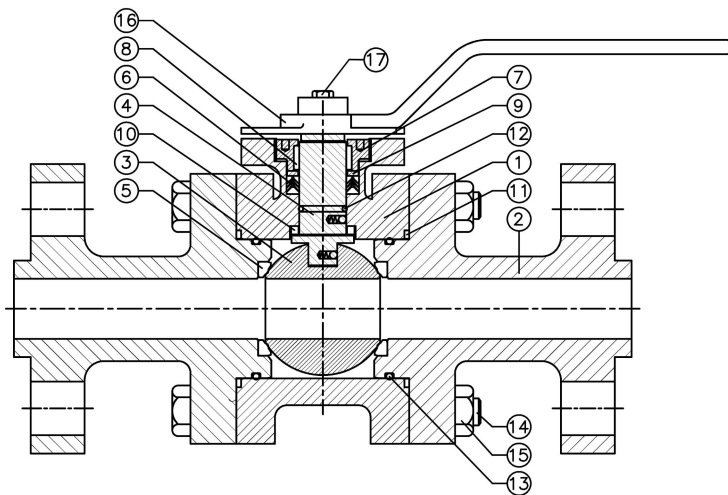

- Industry leading warranty (24 months*)
- Standard Cast (900ASME).
- Triple independent low emission stem seals
- Blow-out proof stem
- Viton O-rings , AED O-rings (Also available)
- Standard seats** : DELRIN (900 ASME); NYLON
- Standard seals** : VITON B , Graphite , PTFE
- Double anti-static protection
- Low torques, High volume with special wide seat design
- General Standards include: BS-5351, ASME B16.34
- Fire safe design (API 607)
- Standard ISO 5211 mounting pads
- Metal seated options available
- Available with different combination ends (i.e Screwed / Socket weld /Butt weld)
- Low emission packing
- GFT thrust-washer and DELRIN gland bearing prevents galling & prevents against deformation
- Extended stem (Available on request)
- Material compliance with NACE specification.



MANUFACTURING RANGE

(Available in full port)

900 ASME
PN 150

1/2"	•	1 1/4"	•	2 1/2"	•
3/4"	•	1 1/2"	•	3"	•
1"	•	2"	•		

ITEM	DESCRIPTIONS	ITEM	DESCRIPTIONS	ITEM	DESCRIPTIONS
1	BODY	12	GLAND BEARING	12	NUT
2	END CONNECTOR	13	SPACER	13	LEVER
3	BALL	14	STEM TRUST WASHER	14	STOPPER
4	STEM	15	BODY SEAL	15	ALLEN BOLT
5	SEAT	16	STEM 'O' RING	16	TAG PLATE
6	STEM SEAL	17	END CONN 'O' RING	17	
7	GLAND	18	STUD	18	

NOTE: Drawings are representative, please contact Sankey Controls for specific and current PDF drawings.
*Sankey limited warranty of 24 months from date of shipment or 18 months from the date of start-up.
** Other materials available upon request.

info@sankeycontrols.com
www.sankeycontrols.com